

# Kidde Fire Systems HPCO2 Component Description



## Pneumatic Heat Detector, Industrial

Effective: April 2022  
K-81-7030 Rev AC

P/N: WK-840845-00

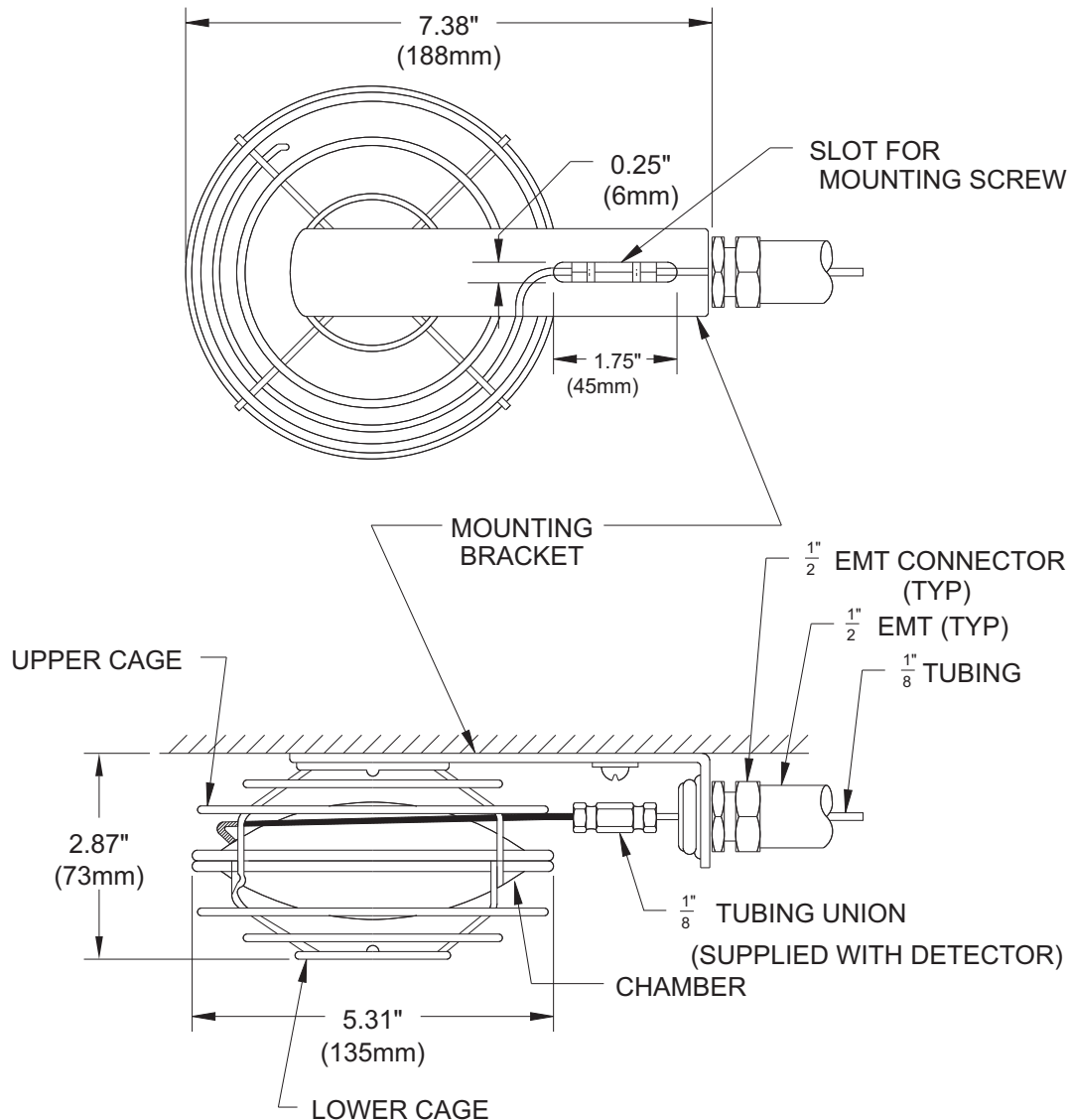

### MATERIALS:

- Cages, Chambers, And Mounting Bracket: Steel
- Finish: Red Paint

### EXPORT INFORMATION (USA)

Jurisdiction: EAR

Classification: EAR99

This document contains technical data subject to the EAR.

All trademarks are the property of their respective owners.

©2022 Carrier

This literature is provided for informational purposes only. KIDDE-FENWAL, INC. believes this data to be accurate, but it is published and presented without any guarantee or warranty whatsoever. KIDDE-FENWAL, INC. assumes no responsibility for the product's suitability for a particular application. The fire suppression system design, installation, maintenance, service and troubleshooting must be performed by trained, authorized Kidde Fire Systems distributors for the product to work correctly. If you need more information on this product, or if you have a particular problem or question, contact KIDDE-FENWAL, INC., Ashland, MA 01721 USA. Telephone: (508) 881-2000.

Kidde Fire Systems  
400 Main Street  
Ashland, MA 01721  
Ph: 508.881.2000  
Fax: 508.881.8920  
[kiddefiresystems.com](http://kiddefiresystems.com)